

TxCell[®] Scanning Laser Delivery System

Operator Manual



TxCell® Scanning Laser Delivery System Operator Manual
70375-EN Rev B 12.2021

© 2021 Iridex Corporation. All rights reserved.

Iridex, the Iridex logo, OcuLight, G-Probe, IQ 532, IQ 577, EndoProbe, and MicroPulse are registered trademarks; TxCell, BriteLight, CW-Pulse, DioPexy, EasyFit, EasyView, FiberCheck, IQ 810, LongPulse, MilliPulse, OtoProbe, PowerStep, Symphony, TruFocus, and TruView are trademarks of Iridex Corporation. All other trademarks are the property of their respective holders.

Contents

1. INTRODUCTION	1
PRODUCT DESCRIPTION	1
IRIDEX CORPORATION CONTACT INFORMATION	1
WARNINGS AND CAUTIONS	2
2. OPERATION	4
ABOUT THE COMPONENTS	4
SET UP TXCELL CONTROL BOX	5
INSTALL TXCELL SSLA	6
TREATMENT SCREEN	10
PATTERN SELECTION SCREEN	11
AIMING BEAM INTENSITY ADJUSTMENT	13
AUTOMATED FIBERCHECK™	13
TREATING PATIENTS	14
3. PATIENT TREATMENT AND CLINICAL INFORMATION	15
INTENDED USE/INDICATIONS FOR USE	15
CONTRAINDICATIONS	16
POTENTIAL SIDE EFFECTS OR COMPLICATIONS	16
SPECIFIC WARNINGS AND PRECAUTIONS	16
PROCEDURAL RECOMMENDATIONS	17
CLINICAL REFERENCES	20
4. TROUBLESHOOTING	21
GENERAL PROBLEMS	21
TXCELL SCANNING LASER DELIVERY SYSTEM ERRORS	22
5. MAINTENANCE	24
6. SAFETY AND COMPLIANCE	26
PROTECTION FOR THE PHYSICIAN	26
PROTECTION FOR ALL TREATMENT ROOM PERSONNEL	26
SAFETY COMPLIANCE	26
LABELS	27
SYMBOLS (AS APPLICABLE)	29
TXCELL SSLA SPECIFICATIONS	30
EMC SAFETY INFORMATION	31

1

Introduction

Product Description

The TxCell® Scanning Laser Delivery System adds the use of pattern scanning technology when coupling with commercially available Iridex laser systems. This offers existing Iridex laser systems the ability to deliver, in addition to standard single-spot applications, a full spectrum of multi-spot pattern scanning options through a variety of customer-owned slit lamps. It is intended for use by trained physicians for the diagnosis and treatment of ocular pathology.

The TxCell Scanning Laser Delivery System consists of the following system components:

- TxCell Scanning Slit Lamp Adapter (SSLA) that may be coupled to Iridex laser workstations, Zeiss or Haag-Streit styles .
- TxCell Control Box with power supply, scanner controller, drive electronics and electrical connections. The Control Box is paired with an SSLA.
- Cables to connect the SSLA to the Control Box and the Control Box to the laser console.

Iridex Corporation Contact Information



Iridex Corporation
1212 Terra Bella Avenue
Mountain View, California 94043-1824 USA

Telephone: (800) 388-4747 (US only)
(650) 940-4700
Fax: (650) 962-0486
Technical Support: (650) 940-4700
(800) 388-4747 (US only)
techsupport@iridex.com



Emergo Europe
Prinsessegracht 20
2514 AP The Hague
The Netherlands



Warranty and Service

This device carries a standard factory warranty. This warranty is void if service is attempted by anyone other than certified Iridex service personnel.

Should you require assistance, please contact your local Iridex Technical Support representative or our corporate headquarters.

NOTE: *This Warranty and Service statement is subject to the Disclaimer of Warranties, Limitation of Remedy, and Limitation of Liability contained in Iridex's Terms and Conditions.*



WEEE Guidance. Contact Iridex or your distributor for disposal information.

Warnings and Cautions

WARNINGS:

Lasers generate a highly concentrated beam of light that may cause injury if improperly used. To protect the patient and the operating personnel, the entire laser and the appropriate delivery system operator manuals should be carefully read and comprehended before operation.

Never look directly into the aiming or treatment beam apertures or the fiber-optic cables that deliver the laser beams with or without laser safety eyewear.

Never look directly into the laser light source or at laser light scattered from bright reflective surfaces. Avoid directing the treatment beam at highly reflective surfaces such as metal instruments.

Ensure that all personnel in the treatment room are wearing the appropriate laser safety eyewear. Never substitute prescription eyewear for laser safety eyewear.

Always keep the Iridex laser in Standby mode when you are not treating a patient. Maintaining the Iridex laser in Standby mode prevents accidental laser exposure if the footswitch is inadvertently pressed.

If you are using a beam splitter, you must install the fixed ESF for the appropriate wavelength before installing the beam splitter.

Avoid over-treatment of targeted tissue by using the lowest power density. Please refer to "Treating Patients" in Chapter 2.

Ensure pattern covers only the desired treatment area prior to footswitch actuation.

Reaction time can exceed rate of treatment spot delivery in either single-spot repeat or multi-spot pattern mode. This can result in delivery of laser applications after intended release of the footswitch prior to completion of a pattern.

The relationship between spot size and resultant power density is not linear. Halving the spot size quadruples the power density. The physician must understand the relationship among spot size, laser power, power density, and laser/tissue interaction before using the TxCell Scanning Slit Lamp Adapter.

Always inspect the fiber-optic cable before connecting it to the laser to ensure that it has not been damaged. A damaged fiber-optic cable could cause accidental laser exposure or injury to yourself, your patient, or others in the treatment room.

Always verify that the delivery device is properly connected to the laser. An improper connection may result in an inadvertent secondary laser beam. Severe eye or tissue damage could occur.

Do not use the delivery device with any laser system other than an Iridex laser. Such use may void product warranties and jeopardize the safety of the patient, yourself, and others in the treatment room.

Tissue absorption is directly dependent upon presence of pigmentation; therefore, dark pigmented eyes will require lower energies to obtain equivalent results as compared to light pigmented eyes.

Observation equipment such as a beam splitter or co-observation tube must be installed between the ESF and the oculars.

To avoid the risk of electric shock, this equipment must only be connected to a supply main with protective earth. EN60601-1:2006/AC; 2010 16-2 (C)

CAUTIONS:

US federal law restricts this device to sale by or on the order of a healthcare practitioner licensed by the law of the State in which he/she practices to use or order the use of the device.

Use of controls or adjustments or performing of procedures other than those specified herein may result in hazardous radiation exposure.

Do not operate the equipment in the presence of flammables or explosives, such as volatile anesthetics, alcohol, and surgical preparation solutions.

Turn off the laser before inspecting any delivery device components.

Always handle the fiber-optic cables with extreme care. Do not coil the cable into a diameter less than 15 cm (6 in).

Keep the protective cap over the fiber-optic connector when the delivery device is not in use.

Do not touch the end of the fiber-optic connector, as finger oils can impair light transmission through the fiber-optic and reduce power.

Do not handle any illumination lamp by its glass bulb.

2 Operation

About the Components

After unpacking the contents of your TxCell® Scanning Laser Delivery System, ensure that you have all of the components ordered.

In addition to the TxCell Scanning Slit Lamp Adapter (SSLA), control box, and control box cable, you may have an Eye Safety Filter (ESF), a split-mirror illumination prism, a finger rest, a micromanipulator, mounting bracket, and installation tools, depending on the slit lamp model. Check the components carefully before use to ensure that no damage occurred during transit.

Slit Lamp Compatibility

Model	Spot Size (µm)	Slit Lamp Styles	Console Compatibility
TxCell SSLA	Single-spot: 50 - 500 Multi-spot: 100 - 500	Iridex SL 980, Iridex SL 990, Zeiss 30 SL, Zeiss SL 130, Haag-Streit BM/BQ 900 and equivalents	IQ 532® / IQ 577®



Typical Slit Lamp Adapter and Components (Depending on Model)

Component	Description
Illumination prism	Projects white light from slit lamp without interference with laser delivery.
Micromanipulator handle	Allows independent beam steering capabilities.
Eye Safety Filter	Protects against laser wavelength reflected back to oculars.
Finger rest	For use when using the micromanipulator.
Spacer	As necessary, depending on TxCell SSLA model.
Mounting bracket	As necessary, depending on TxCell SSLA model.
Slit lamp table	Diagnostic system to which TxCell SSLA attaches (workstation component).
Fiber-optic cable	Transmits laser light.
SSLA Control cable	Communicates spot size, filter information, and scanning information to the control box.
Control box	Houses the power supply, scanner controller, and electrical components
Control box cable	Connects the control box to the laser console

Set Up TxCell Control Box

1. Place the laser console on top of the Control Box (preferred, or as space permits). If brought in from the cold, wait for the temperature of the system to warm up to room temperature.
2. Connect Control Box to laser console using the provided Control Box Cable.
3. Connect Control Box to electrical outlet.

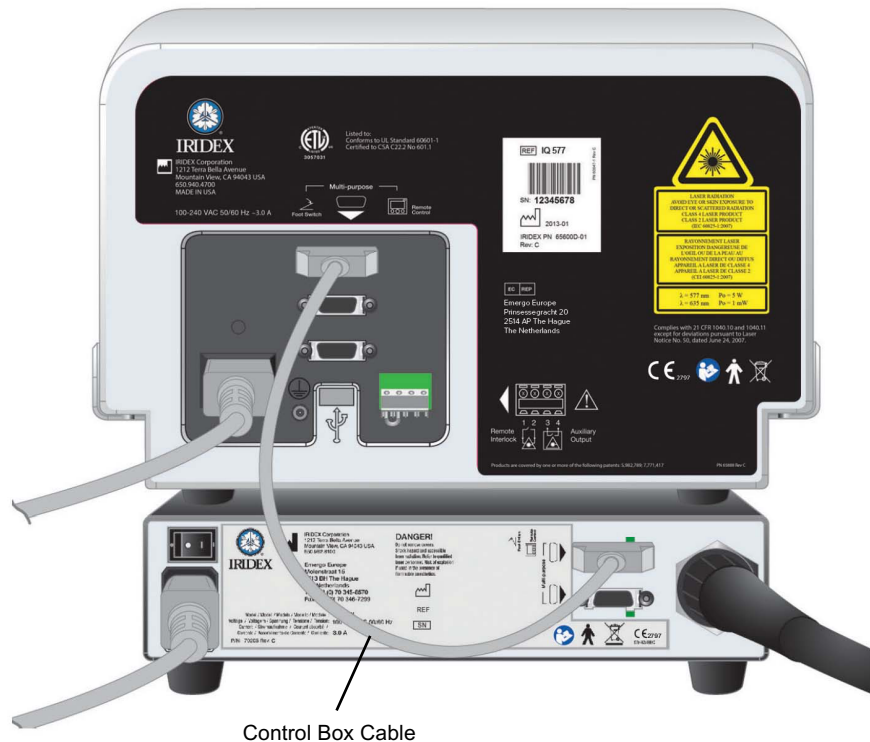

Install TxCell SSLA

1. Lock slit lamp in place.
2. Move illumination tower out of the way.
3. For Haag-Streit equivalent: Install mounting bracket or spacer as necessary.

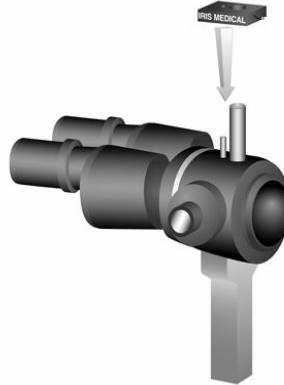

4. For Haag-Streit equivalent: Unlatch ESF from storage position. Place SLA on the post of the slit lamp microscope. Tighten with thumbscrew.



5. For Zeiss equivalent: Install Eye Safety Filter (ESF) to the slit lamp oculars per the images below (as applicable).



6. Install micromanipulator handle and finger rest (as applicable). Tighten with thumbscrews.



- Secure fiber-optic cable to the slit lamp using the supplied Velcro straps, while maintaining a minimum loop diameter of 15cm in the fiber-optic cable.

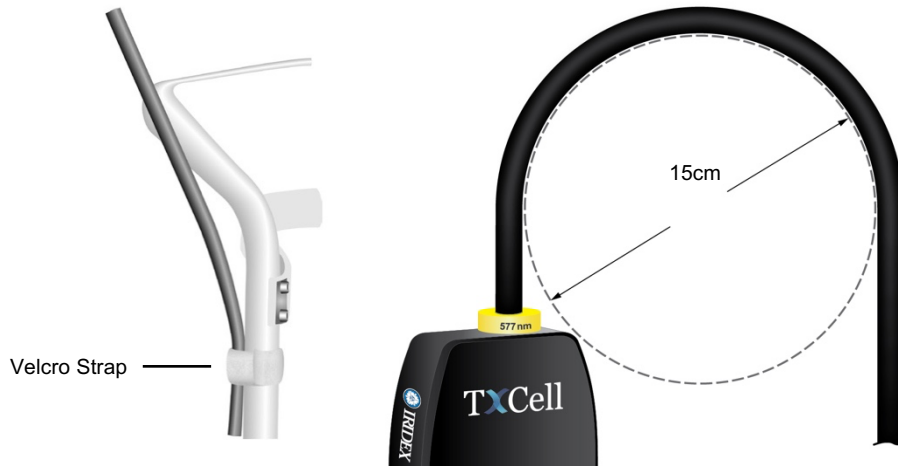

- Connect fiber-optic cable to the laser console.

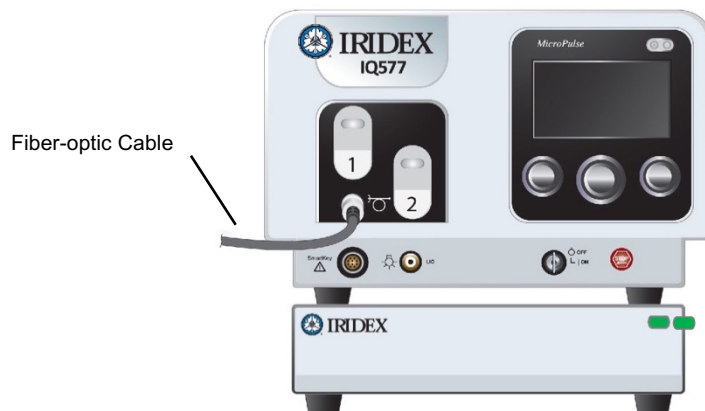

- Plug SSLA Control cable into TxCell Control Box. The connector will align in a specific orientation. Push in and rotate clockwise until fully seated.



Verify Alignment of Aiming Beams

1. Turn the TxCell Control Box on using the service power switch on the back of the Control Box. The service power switch can remain on.
2. Turn the laser console key to On. Wait about 40 seconds for the Pattern button to appear.
3. Select 500-micron spot size on SSLA.



4. Install the focus post of the slit lamp or a card from the forehead rest. Press the Pattern button and look through the slit lamp to confirm that the aiming beams are aligned. For this purpose, visually inspect that the projected circle is centered within the square. Both the circle and the square will appear to flash. If the observed circle is outside of the square, please contact your local Iridex Technical Support representative.

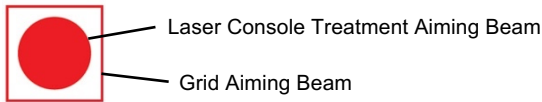

5. If aligned, press OK.

Verify the Focus

1. Adjust slit lamp oculars to appropriate diopter setting.
2. Turn on Iridex laser to see aiming beam.
3. In single-spot mode, use X and Y adjustments to center aiming beam in illumination slit.
4. In single-spot mode, use Z adjustment knob for fine focus.
5. Activate a pattern from the Pattern Selection Screen and ensure Target Grid is also in focus. (If Target Grid is not in focus or appears to be only a partial Target Grid, please refer to Chapter 4, "Troubleshooting.")



Set the Two-Position ESF

1. Move lever to closed position to view through the laser Eye Safety Filter and enable laser treatment.
2. Move to open position to obtain a clear view unimpeded by a laser Eye Safety Filter.

NOTE: As a safety precaution, the laser is unable to enter Treat mode while the Eye Safety Filter is open.

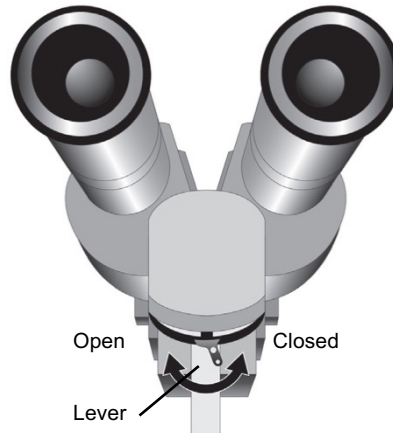

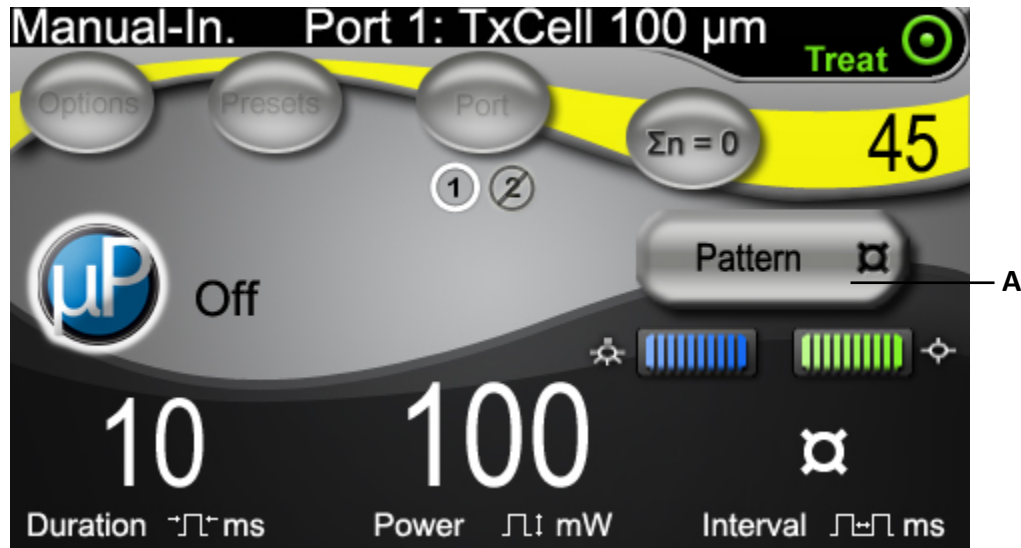

Treatment Screen

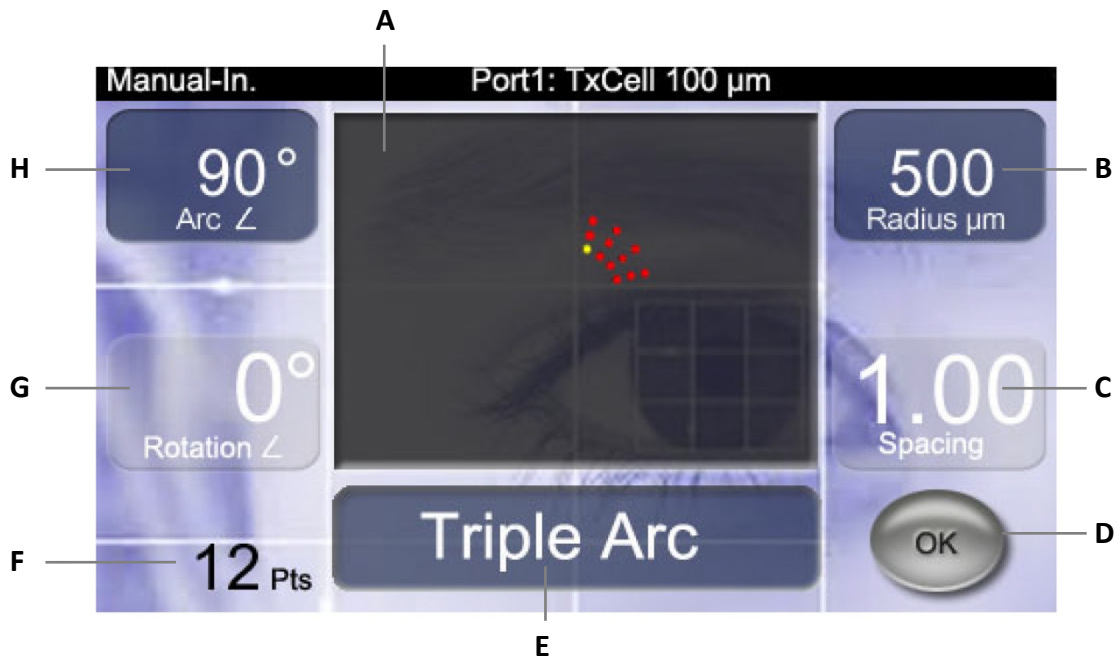

- A** Button to access Pattern Selection Screen for multi-spot applications.

Pattern Selection Screen

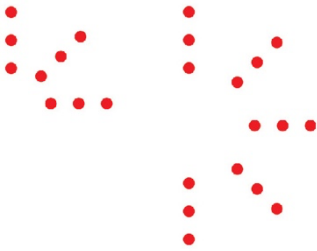

A	Displays selected pattern.
B	<p>Right control knob selects Radius in microns (Triple Arc, Circle only). The radius is the distance from the origin to the inner edge of nearest treatment spot. There will be a different minimum and maximum Radius range based on the selected treatment spot diameter; for example, a pattern with a 100-micron spot will have a minimum Radius of 500 microns. Examples:</p> 
C	<p>Right control knob selects Spacing between spots (Grid, Triple Arc, Circle only). The spacing is the distance between the inner edges of a pair of spots. Spacing is displayed as increments of spot size diameters, and is adjustable from 0.0 to 3.0 in 0.25 spot size increments; for example, a pattern with a 100-micron spot with 1.00 spacing will have a 100-micron spacing between spots. Examples:</p> 
D	Confirms pattern scanning selection and returns to Treatment Screen.
E	Middle control knob selects pattern type: Grid 2x2, Grid 3x3, Grid 4x4, Grid 5x5, Grid 6x6, Grid 7x7, Triple Arc, Circle.
F	Displays total number of laser spots for selected pattern.

<p>G</p>	<p>Left control knob adjusts the Rotation of the pattern (Grid, Triple Arc only). Examples:</p> 
<p>H</p>	<p>Left control knob increases or decreases the Arc angle of the pattern. (min. 45° to max. 360°, in increments of 45°). Examples:</p> 

NOTE: Patterns that exceed a maximum retinal dimension or number of spots are not selectable. For example, with a 7x7 Grid and a 500-micron spot size, spacings over 2.25 are not selectable.

Examples of Visualized Target Grid

Each pattern will produce a laser Target Grid that is visualized through the slit lamp. The projected Target Grid will have a spot centered within one of the cells. This spot identifies the size of the associated treatment beam and the cell in which the multi-spot pattern will initiate. This spot is continuously illuminated in CW-mode, and it flashes to indicate when MicroPulse mode has been activated.

In CW-mode, the Target Grid is displayed before, and then after each treatment pattern is completed, i.e. when the footswitch is pressed, the Target Grid will disappear, the treatment pattern will begin, and then reappear when the pattern is completed.

In MicroPulse-mode, the Target Grid is continuously displayed during treatment.

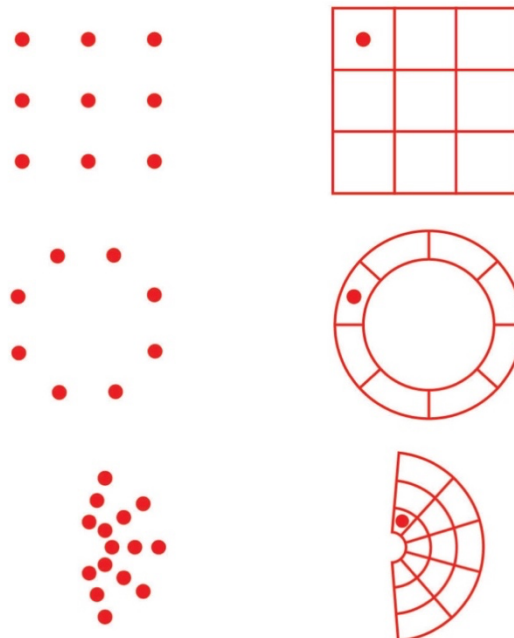

Aiming Beam Intensity Adjustment

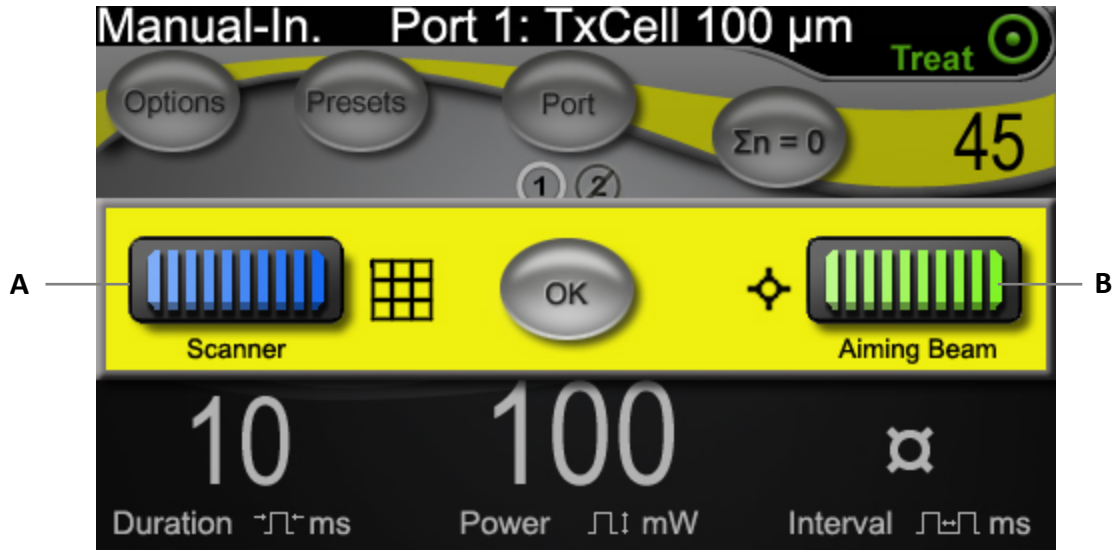

A	Aiming Beam & Target Grid intensity during pattern scanning mode
B	Aiming Beam intensity during single-spot mode

Automated FiberCheck™

FiberCheck is an automated test to determine fiber integrity. If the fiber needs replacement, the following prompt will appear: "Fiber Check: Fail. Call Service." Prompt does not prevent continued use of device.

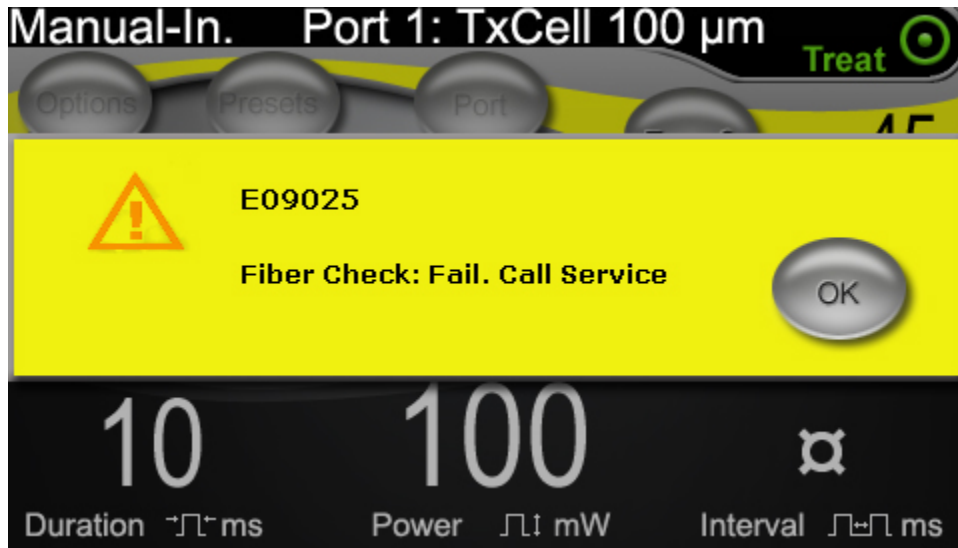

Treating Patients

BEFORE TREATING A PATIENT:

- Ensure that the eye safety filter is properly installed.
- Ensure that the laser components and delivery device(s) are properly connected.
- Post the laser warning sign outside the treatment room door.

NOTE: Refer to Chapter 6, "Safety and Compliance," and your delivery device manual(s) for important information about laser safety eyewear and eye safety filters.

TO TREAT A PATIENT:

1. Turn the TxCell Control Box on using the service power switch on the back of the Control Box.
2. Turn on the laser.
3. Reset the counter.
4. Position the patient.
5. Select a laser contact lens appropriate for the treatment. Use caution when operating with a multiple mirror laser contact lens in multi-spot mode. Do not overfill the mirror with the pattern and ensure that you have visualization of the complete pattern and the area to be treated prior to laser treatment.
6. Ensure that all ancillary personnel in the treatment room are wearing the appropriate laser safety eyewear.
7. Select Treat mode.
8. Ensure use of lowest aiming beam intensity possible.
9. Position the aiming beam or Target Grid on the treatment site.
10. Confirm focus and adjust the delivery device as applicable.
11. To titrate laser power, perform single-spot test exposure prior to initiating treatment. If uncertain of expected clinical response, always start with conservative settings and increase laser power and/or duration setting in small steps.
 - a. Please ensure repeat mode is off when titrating.
12. Select final laser treatment parameters, including multi-spot pattern or repeat mode if desired.
 - a. Please note that repeat mode is available only with single-spot mode. There is a 10 ms minimum time interval with single-spot repeat mode.
 - b. Please note that multi-spot pattern mode is available with 100 μm and larger spot sizes. There is a 2 ms minimum time interval between successive spots with multi-spot pattern mode.
13. Press the footswitch to initiate treatment delivery. Release the footswitch at any time to immediately terminate treatment laser emission, including any incomplete patterns.
 - a. Please note that one actuation of the footswitch will deliver one multi-spot pattern when held for the duration of the pattern.

TO CONCLUDE PATIENT TREATMENT:

1. Select Standby mode.
2. Record the number of exposures and any other treatment parameters.
3. Turn off the laser system and remove the key. The TxCell Control Box service power switch can remain on.
4. Collect the safety eyewear.
5. Remove the warning sign from the treatment room door, if appropriate.
6. Disconnect the delivery device(s).
7. If a contact lens was used, handle the lens according to the manufacturer's instructions.

3

Patient Treatment and Clinical Information

This chapter provides information on the use of the TxCell® Scanning Laser Delivery System for the treatment of ocular pathologies, including specific indications and contraindications, procedural recommendations, and a list of clinical references. The information in this chapter is not intended to be all-inclusive, nor is it intended to replace surgeon training or experience.

Intended Use/Indications for Use

When the TxCell Scanning Laser Delivery System is connected to the IQ 532® (532 nm) or the IQ 577® (577 nm) Laser Console, from the Iridex Family of IQ Laser Systems and used to deliver laser energy in CW-Pulse, MicroPulse® or LongPulse mode, it is intended to be used by a trained ophthalmologist for the treatment of ocular pathology of both the anterior and posterior segments of the eye.

532 nm

Indicated for retinal photocoagulation, laser trabeculoplasty, iridotomy, iridoplasty including:

Retinal photocoagulation (RPC) for the treatment of:

Diabetic retinopathy, including:

Nonproliferative retinopathy

Macular edema

Proliferative retinopathy

Retinal tears and detachments

Lattice degeneration

Age-related macular degeneration (AMD) with choroidal neovascularization (CNV)

Sub-retinal (choroidal) neovascularization

Central and branch retinal vein occlusion

Laser trabeculoplasty for the treatment of:

Primary open angle glaucoma

Laser iridotomy, iridoplasty for the treatment of:

Angle closure glaucoma

577 nm

Indicated for use in photocoagulation of both anterior and posterior segments including:

Retinal photocoagulation, panretinal photocoagulation of vascular and structural abnormalities of the retina and choroid including:

Proliferative and nonproliferative diabetic retinopathy

Choroidal neovascularization

Branch retinal vein occlusion

Age-related macular degeneration (AMD) with choroidal neovascularization (CNV)

Retinal tears and detachments

Laser trabeculoplasty for the treatment of:

Primary open angle glaucoma

Laser iridotomy, iridoplasty for the treatment of:

Angle closure glaucoma

Contraindications

- Any situation where the target tissue cannot be adequately visualized or stabilized.
- Do not treat albino patients that have no pigmentation.

Potential Side Effects or Complications

- Specific to retinal photocoagulation: inadvertent foveal burns; choroidal neovascularization; paracentral scotomata; transient increased edema/ decreased vision; subretinal fibrosis; photocoagulation scar expansion; Bruch's membrane rupture; choroidal detachment; exudative retinal detachment; pupillary abnormalities from damage to the ciliary nerves; and, optic neuritis from treatment directly or adjacent to the disc.
- Specific to laser iridotomy or iridoplasty: inadvertent corneal or lens burns/opacities; iritis; iris atrophy; bleeding; visual symptoms; IOP spike; and, rarely retinal detachment.
- Specific to laser trabeculoplasty: IOP spike, and, disruption of the corneal epithelium.

Specific Warnings and Precautions

It is essential that the surgeon and attending staff be trained in all aspects of the use of this equipment. Surgeons should obtain detailed instructions for proper use of this laser system before using it to perform any surgical procedures.

For additional Warnings and Cautions, refer to Chapter 1, "Introduction." For more clinical information, see "Clinical References" at the end of this chapter.

Proper eye protection must be utilized for the specific treatment laser wavelength in use (532 nm or 577 nm).

Multi-spot mode is intended for retinal photocoagulation only.

For patients with wide variations in retinal pigmentation as evaluated by ophthalmoscopic observation, select multi-spot patterns which cover a homogeneously pigmented smaller area to avoid unpredictable tissue damage.

Exercise caution while setting multi-spot parameters (pulse duration and the number of spots per pattern) when CW laser burns are to be delivered in the macula; with longer grid completion times, the possibility of patient movement increases the risk of treatment of unintended targets.

Procedural Recommendations

IMPORTANT ELEMENTS OF EVERY LASER PHOTOCOAGULATION PROCEDURE

Ophthalmic laser photocoagulation has a decades-long history of successfully providing durable clinical outcomes that are both meaningful and beneficial to the patient. It is important, however, to consider the various hardware controls and adjustments, their interactions with one another, and each patient's needs to achieve the best possible clinical results. These considerations include:

- **Spot Size**
Spot size at target is dependent on many parameters, including physician's selection of laser spot size and choice of laser delivery lens, patient's refractive power, and proper focus of the aiming laser on the target.
- **Laser Power**
If uncertain of tissue response, start with lower power settings and increase the power until satisfactory clinical results are achieved.
- **Power, Spot Size, and Power Density**
Power density is the ratio of laser power to the area of the spot size. Tissue response to laser light of a given wavelength is strongly determined by power density. To increase power density, increase the laser power or decrease the spot size. Because power density varies with the square of spot size, this parameter is an especially sensitive factor.
- **Red Aiming and Treatment Laser Beams**
In single-spot mode, always ensure that the aiming beam is in sharp focus on the intended target prior to and during laser delivery. Out-of-focus spots can have less consistent power density at the target and may not produce clinically satisfactory results.

In multi-spot mode, always ensure that the target grid is in sharp focus prior to laser delivery. An out-of-focus target grid may not produce clinically satisfactory results.
- **Exposure Duration, Heat Flow, and Spacing Between Spots**
When absorbed by ocular chromophores such as melanin and hemoglobin, laser energy is converted into kinetic energy (heat). This heat flows from hotter tissue to cooler tissues nearby. This conduction of heat in all directions away from directly irradiated tissue begins with the initiation of the laser exposure and continues throughout the exposure, and even after its end, until thermal equilibrium is regained. Therefore, longer exposure durations are associated with greater conduction distances, while shorter exposures have smaller conduction distances. Thus, it may be clinically beneficial to space adjacent laser spots more closely when using short CW-pulse durations,¹³ and even more closely when using MicroPulse mode.¹²
- **MicroPulse Mode and Thermal Confinement**
MicroPulse mode is a method of laser delivery that helps to confine thermal effects to specifically targeted tissues by reducing heat conduction during the laser treatment. This is achieved by automatically delivering laser energy as a train of brief pulses, instead of as a single, uninterrupted exposure of much longer duration as used during CW-Pulse laser delivery. In contrast to "constant energy" laser systems, shortening the exposure time in MicroPulse mode does not increase peak power. MicroPulse mode can be thought as a CW-Pulse that has been chopped into a number of shorter pieces by introducing brief periods of off-time. The off-time between each sequential MicroPulse application allows tissue to cool, reducing collateral thermal effects to the nearby tissue. MicroPulse mode can result in lighter and smaller laser lesions.

- **MicroPulse Duty Cycle**

Typical MicroPulse treatment settings deliver 500 MicroPulse applications per second. 500 Hz defines a 2-millisecond (ms) period, which is the sum of Laser ON time + Laser OFF time.

MicroPulse duty cycle examples:

- 5% duty cycle = 0.1 ms ON + 1.9 ms OFF time
- 10% duty cycle = 0.2 ms ON + 1.8 ms OFF time
- 15% duty cycle = 0.3 ms ON + 1.7 ms OFF time

In contrast, a Continuous Wave (CW) exposure, which is always ON, can be thought of as having a duty cycle of 100%.

- **Spacing Between Spots and Duty Cycle**

MicroPulse applications, especially those produced using lower duty cycles, produce less thermal diffusion. In order to effect a sufficient volume of target tissue to achieve a desired therapeutic effect, MicroPulse laser applications must be more closely spaced, or even contiguous (0 spacing).¹²

- **Patient Sensitivity to Photocoagulation**

Some patients report a more heightened level of sensation or pain during laser photocoagulation. Patient comfort can often be significantly enhanced by appropriate use of the following treatment parameters and considerations:

- Shorter pulses (<50 ms)
- Smaller spot sizes
- Lower energy pulses
- Milder laser lesion endpoints

Also, the peripheral retina is both thinner and more sensitive than the posterior retina. Laser treatment parameters may need to be readjusted when treating the peripheral retina.

Laser Settings

It is the physician's responsibility to determine the appropriate treatment parameters for each patient being treated. The information in the following tables is intended to provide guidance only for treatment settings, which are not prescriptive for any condition. The operative needs of each patient should be individually evaluated based on the specific indication, treatment location, and patient-specific characteristics. If uncertain of expected clinical response, always start with conservative settings and increase laser power and/or duration settings in small steps. Proper delivery of both CW and MicroPulse laser is verified as delivered by internal power monitoring controls, within the respective laser console.

532 NM TYPICAL LASER TREATMENT PARAMETERS FOR OCULAR PHOTOCOAGULATION

(Please note that multi-spot pattern mode is available with 100 µm and larger spot sizes.)

532 nm Continuous Wave Treatment			
Treatment	Spot Size at Target (µm)	Power (mW)	Exposure Duration (ms)
Retinal Photocoagulation	50 - 1000	50 - 2000	10 - 1000
Trabeculoplasty	50 - 200	500 - 2000	100 - 500
Iridotomy	50 - 200	500 - 2000	100 - 300

532 nm MicroPulse Treatment*				
Treatment	Spot Size at Target (µm)	Power (mW)	Duty Cycle (500 Hz)	Exposure Duration (ms)
Retinal Photocoagulation	50 - 1000	100 - 2000	2.5% to 25%	10 - 1000
Trabeculoplasty	100 - 500	500 - 2000	2.5% to 25%	100 - 500

577 NM TYPICAL LASER TREATMENT PARAMETERS FOR OCULAR PHOTOCOAGULATION

(Please note that multi-spot pattern mode is available with 100 µm and larger spot sizes.)

577 nm Continuous Wave Treatment			
Treatment	Spot Size at Target (µm)	Power (mW)	Exposure Duration (ms)
Retinal Photocoagulation	50 - 1000	50 - 2000	10 - 1000
Trabeculoplasty	50 - 200	500 - 2000	100 - 500
Iridotomy	50 - 200	200 - 2000	100 - 300

577 nm MicroPulse Treatment*				
Treatment	Spot Size at Target (µm)	Power (mW)	Duty Cycle (500 Hz)	Exposure Duration (ms)
Retinal Photocoagulation	50 - 1000	100 - 2000	2.5% to 25%	10 - 1000
Trabeculoplasty	100 - 500	500 - 2000	2.5% to 25%	100 - 500

* MicroPulse mode can result in lighter and smaller laser lesions.

Clinical References

1. [No authors listed.] Photocoagulation Treatment of Proliferative Diabetic Retinopathy: The Second Report of Diabetic Retinopathy Study Findings. *Ophthalmology* 1978;85(1):82-106.
2. Early Treatment of Diabetic Retinopathy Study Research Group. Photocoagulation for Diabetic Macular Edema. Early Treatment Diabetic Retinopathy Study Report Number 1. *Arch Ophthalmol* 1985;103(12):1796-806.
3. Brancato R, Carassa R, Trabucchi G. Diode Laser Compared with Argon Laser for Trabeculoplasty. *Am J Ophthalmol* 1991;112(1):50-5.
4. Akduman L, Olk RJ. Diode Laser (810 Nm) Versus Argon Green (514 Nm) Modified Grid Photocoagulation for Diffuse Diabetic Macular Edema. *Ophthalmology* 1997;104(9):1433-41.
5. Desmettre TJ, Mordon SR, Buzawa DM, Mainster MA. Micropulse and Continuous Wave Diode Retinal Photocoagulation: Visible and Subvisible Lesion Parameters. *Br J Ophthalmol* 2006;90(6):709-12.
6. Parodi MB, Spasse S, Iacono P, Di Stefano G, Canziani T, Ravalico G. Subthreshold Grid Laser Treatment of Macular Edema Secondary to Branch Retinal Vein Occlusion with Micropulse Infrared (810 Nanometer) Diode Laser. *Ophthalmology* 2006;113(12):2237-42.
7. Al-Hussainy S, Dodson PM, Gibson JM. Pain Response and Follow-up of Patients Undergoing Panretinal Laser Photocoagulation with Reduced Exposure Times. *Eye (Lond)* 2008;22(1):96-9.
8. Fea AM, Bosone A, Rolle T, Brogliatti B, Grignolo FM. Micropulse Diode Laser Trabeculoplasty (Mdl): A Phase II Clinical Study with 12 Months Follow-Up. *Clin Ophthalmol* 2008;2(2):247-52.
9. Luttrull JK, Musch DC, Spink CA. Subthreshold Diode Micropulse Panretinal Photocoagulation for Proliferative Diabetic Retinopathy. *Eye (Lond)* 2008;22(5):607-12.
10. Muqit MM, Marcellino GR, Henson DB, Young LB, Patton N, Charles SJ, Turner GS, Stanga PE. Single-Session Vs Multiple-Session Pattern Scanning Laser Panretinal Photocoagulation in Proliferative Diabetic Retinopathy: The Manchester Pascal Study. *Arch Ophthalmol* 2010;128(5):525-33.
11. Muqit MM, Sanghvi C, McLauchlan R, Delgado C, Young LB, Charles SJ, Marcellino GR, Stanga PE. Study of Clinical Applications and Safety for Pascal (R) Laser Photocoagulation in Retinal Vascular Disorders. *Acta Ophthalmol* 2010.
12. Vujosevic S, Bottega E, Casciano M, Pilotto E, Convento E, Midea E. Microperimetry and Fundus Autofluorescence in Diabetic Macular Edema: Subthreshold Micropulse Diode Laser Versus Modified Early Treatment Diabetic Retinopathy Study Laser Photocoagulation. *Retina* 2010;30(6):908-916.
13. Palanker D, Lavinsky D, Blumenkranz MS, Marcellino G. The Impact of Pulse Duration and Burn Grade on Size of Retinal Photocoagulation Lesion: Implications for Pattern Density. *Retina* 2011;31(8):1664-9.
14. Samples JR, Singh K, Lin SC, Francis BA, Hodapp E, Jampel HD, Smith SD. Laser Trabeculoplasty for Open-Angle Glaucoma: A Report by the America Academy of Ophthalmology. *Ophthalmology* 2011.
15. Sheth S, Lanzetta P, Veritti D, Zucchiatti I, Savorgnani C, Bandello F. Experience with the Pascal (R) Photocoagulator: An Analysis of over 1,200 Laser Procedures with Regard to Parameter Refinement. *Indian J Ophthalmol* 2011;59(2):87-91.
16. Chappelov AV, Tan K, Waheed NK, Kaiser PK. Panretinal Photocoagulation for Proliferative Diabetic Retinopathy: Pattern Scan Laser Versus Argon Laser. *Am J Ophthalmol* 2012;153(1):137-42 e2.

4 Troubleshooting

General Problems

Problem	User Action(s)
No display	<ul style="list-style-type: none"> • Verify that the keyswitch is on. • Verify that the components are properly connected. • Verify that the electrical service is on. • Inspect the fuses. <p>If there is still no display, contact your local Iridex Technical Support representative.</p>
Inadequate or no aiming beam	<ul style="list-style-type: none"> • Verify that the delivery device is properly connected. • Verify that the console is in Treat mode. • Turn the aiming beam control fully clockwise. • Verify that the fiber-optic connector is not damaged. • If possible, connect another Iridex delivery device and place the console in Treat mode. <p>If the aiming beam is still not visible, contact your local Iridex Technical Support representative.</p>
No treatment beam	<ul style="list-style-type: none"> • Verify that the remote interlock has not been activated. • Verify that the aiming beam is visible. • Verify that the eye safety filter is in the closed position. <p>If there is still no treatment beam, contact your local Iridex Technical Support representative.</p>
No Pattern Selection button visible on Treatment Screen	<ul style="list-style-type: none"> • Turn laser console off. • Turn Control Box on. • Turn laser console on. • Wait 40 seconds. <p>If there is still no Pattern Selection button, contact your local Iridex Technical Support representative.</p>
Blurry, inadequate, or partial Target Grid	<ul style="list-style-type: none"> • Verify that the delivery device is properly connected. • Verify that the fiber-optic connector is not damaged. • Verify that the oculars are set to appropriate diopter settings. • Turn the Target Grid aiming beam intensity to maximum. • Adjust the slit illumination to lowest intensity that still maintains comfortable and complete clinical view of the targeted area. • Adjust Z adjustment knob to ensure Target Grid is in focus. • If there is a partial Target Grid, verify that the split-mirror illumination prism is not obstructing the aiming beam. Use X and Y adjustments to center the aiming beam. <p>If there is still a blurry, inadequate, or partial Target Grid, contact your local Iridex Technical Support representative.</p>

TxCell Scanning Laser Delivery System Errors

Please record the Error Code and contact your local Iridex Technical Support representative.

Display	Error Type	Description
E09001 Scanner checksum error	Call Service	Scanner software checksum error.
E09002 Scanner incompatible version	Call Service	The IQ laser is incompatible with the scanner.
E09003 Serial number mismatch	Warning	Serial number mismatch between the scanner Control Box and the scanner head. Will not allow user to enter Treat mode.
E09005 Interlock board not found	No Error Displayed on Screen	Interlock board not found. Usually caused by interlock board not being connected to the embedded PC. Five (5) audible beeps generated by the scanner indicate the error.
E09006 Scanner head not connected	Warning	Scanner head not found. Usually caused by the rear round connector not being connected.
E09008 Fan1 speed out of range	Warning	Blower fan speed out of range. User allowed to continue using scanner system.
E09009 Fan2 speed out of range	Warning	Chassis fan speed out of range. User allowed to continue using scanner system.
E09010 Fan3 speed out of range	Warning	Chassis fan speed out of range. User allowed to continue using scanner system.
E09011 +12V power supply out of range	Call Service	+12V power supply out of range.
E09012 +5V power supply out of range	Call Service	+5V power supply out of range.
E09013 +3.3V power supply out of range	Call Service	+3.3V power supply out of range.
E09014 -5V power supply out of range	Call Service	-5V power supply out of range.
E09015 Invalid temperature readings	Call Service	Driver temperature sensor fault. Can be caused by a disconnected or failed driver thermistor.
E09016 Invalid temperature readings	Call Service	Chassis temperature sensor fault. Usually caused by a disconnected or failed driver thermistor.
E09017 Heatsink temperature exceeded	Warning	Driver operating temperature exceeded. After the temperature drops to a valid operating temperature, user can continue using the scanner system.
E09018 Chassis temperature exceeded	Warning	Chassis operating temperature exceeded. After the temperature drops to a valid operating temperature, user can continue using the scanner system.
E09019 Scanner paused	Warning	Scanner is paused. Occurs after 5 minutes of user inactivity.
E09021 SLA not calibrated	Call Service	SLA PCBA is not calibrated.

Display	Error Type	Description
E09022 Laser console version too old	No Error Displayed on Screen	Laser console version too old to support the scanner. Three (3) audible beeps generated by the scanner indicate the error.
E09023 Laser console not found	No Error Displayed on Screen	Laser console is not found (i.e., not attached to the scanner). Four (4) audible beeps generated by the scanner indicate the error.
E09025 Fiber Check: Fail. Call Service	Call Service	The fiber optic integrity may have been compromised.
E09500 Scanner controller not found	Call Service	Scanner hardware not found. Can be caused by a disconnected internal cable or internal hardware failure.
E09501 Mirror motion error	Warning	Scanner mirrors moved during treatment, and the current scan pattern has terminated prematurely. User is allowed to start a new treatment.
E09502 Laser did not fire	Warning	IQ laser did not fire when requested, and the current scan pattern has terminated prematurely. User is allowed to start a new treatment.
E09503 Scanner needs calibration	Call Service	Scanner is not calibrated or calibration was corrupted.
E09505 Scanner static self-test error	Call Service	Scanner power-on self-test (POST) of no movement failed (i.e., circuitry reported that the scanner was moving when it was not).
E09506 Scanner X-axis POST error: AT H	Call Service	Scanner POST of X-axis movement failed. At Position signal is always high.
E09508 Scanner Y-axis POST error: AT H	Call Service	Scanner POST of Y-axis movement failed. At Position signal is always high.
E09510 Scanner unexpectedly stopped	Warning	Scanner unexpectedly stopped while scanning a pattern.
E09512 Scanner busy POST error	Warning	Scanner reported busy when it should have been idle.
E09513 Scanner idle POST error	Warning	Scanner reported idle when it should have been busy.
E09514 Scanner driver fault	Warning	X or Y axis Cambridge driver fault signal is asserted.

5

Maintenance

TO PROVIDE ROUTINE CARE:

- Do not kink or bend the fiber-optic cable.
- When connected to the laser, the fiber-optic cable must be located away from high traffic areas.
- Keep the optical components free of fingerprints.
- Keep the SSLA attached to the slit lamp, unless you need to transport it or attach a different delivery device.
- When not in use, cover the slit lamp with the provided cover to keep the slit lamp free of dust, and store all accessories in suitable storage boxes.

CLEANING EXTERNAL SURFACES:

Remove accumulated dust with a very soft cloth. When necessary, wipe the external non-optical surfaces with a soft cloth dampened with a mild detergent.

REPLACING THE SLIT LAMP ILLUMINATION LAMP:

Refer to your slit lamp manual for detailed instructions on replacing the illumination lamp. Always replace with an identical type of bulb.

TO REPLACE THE SLIT LAMP ILLUMINATION BULB:

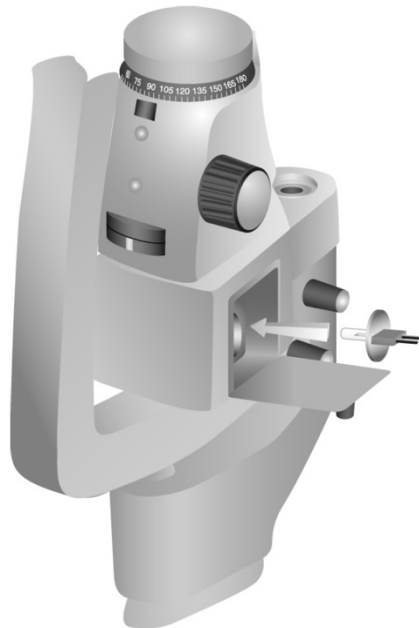

TO CHECK AND CHANGE SLIT LAMP FUSES:

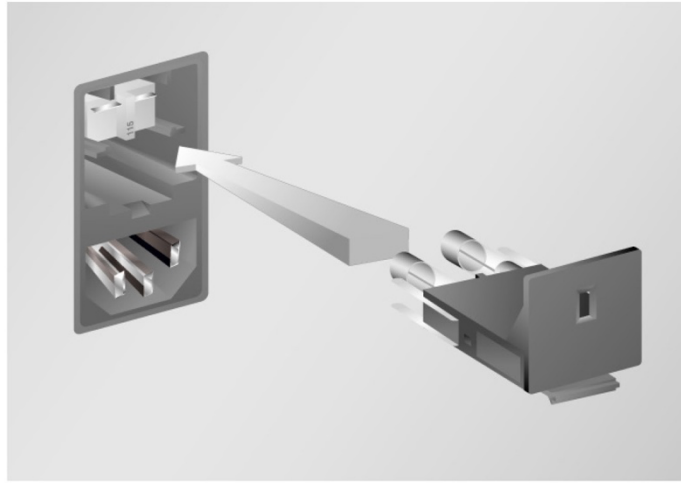

6

Safety and Compliance

To ensure safe operation and prevent hazards and unintended exposure to the laser beams, read and follow these instructions:

- To prevent exposure to laser energy, except as a therapeutic application from either direct or diffusely reflected laser beams, always review and observe the safety precautions outlined in the operator manuals before using the device.
- This device is intended for use only by a qualified physician. The applicability of the equipment and treatment techniques selected is your sole responsibility.
- Do not use any device if you think it is not functioning properly.
- Laser beams reflected from specular surfaces can harm your eyes, the patient's eyes, or others' eyes. Any mirror or metal object that reflects the laser beam can constitute a reflection hazard. Be sure to remove all reflection hazards near the laser. Use non-reflecting instruments whenever possible. Be careful not to direct the laser beam at unintended objects.

CAUTION: *Changes or modifications not expressly approved by the party responsible for compliance could void the user's authority to operate the equipment.*

Protection for the Physician

Eye safety filters protect the physician from backscattered treatment laser light. Integral eye safety filters are permanently installed in the Slit Lamp Adapter, LIO, EasyFit Adapter, Iridex Integrated Slit Lamp Workstation, SL130 Integrated Slit Lamp Workstation, and TxCell Scanning Slit Lamp Adapter. All eye safety filters have an optical density (OD) at the laser wavelength sufficient to permit long-term viewing of diffuse laser light at Class I levels.

Protection for All Treatment Room Personnel

The Laser Safety Officer should determine the need for safety eyewear based on the Maximum Permissible Exposure (MPE), Nominal Ocular Hazard Area (NOHA), and Nominal Ocular Hazard Distance (NOHD) for each of the delivery devices used with the laser system, as well as the configuration of the treatment room. For additional information, refer to ANSI Z136.1, ANSI Z136.3, or European Standard IEC 60825-1.

Always wear laser safety eye wear when performing or observing laser treatments with the unaided eye.

Safety Compliance

Complies with FDA performance standards for laser products, except for deviations pursuant to Laser Notice No. 50, dated June 24, 2007.

CE-labeled devices comply with all requirements of the European Medical Device Directive MDD 93/42/EEC.

Labels

NOTE: The actual label may vary with laser model.

Serial Number and CE Label

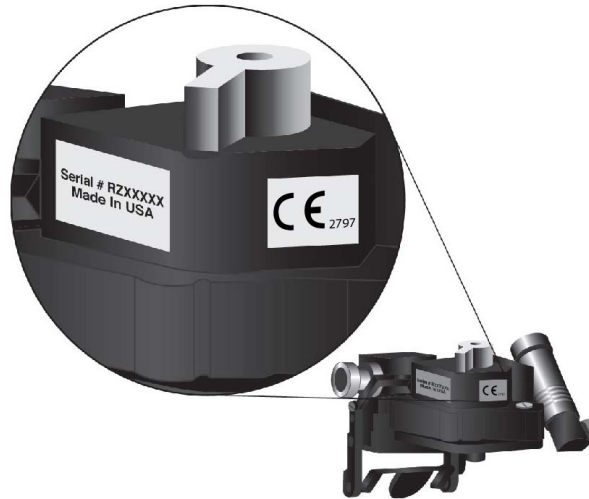

Wavelength Label

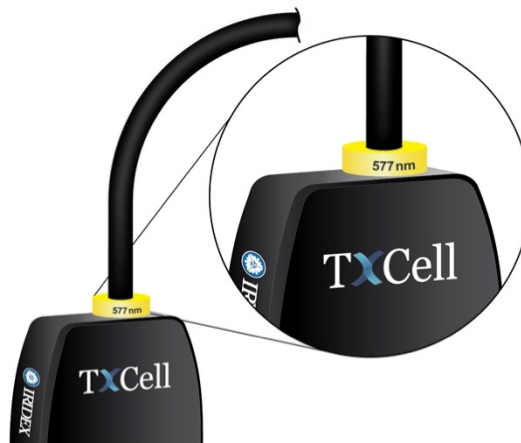

ESF Wavelength Label



Laser Aperture, Laser Emission Labels



Control Box Back Label



IRIDEX

IRIDEX Corporation
1212 Terra Bella Avenue
Mountain View, CA 94043 USA
650.962.8100

EC REP Emurgo Europe
Prinsessegracht 20
2514 AP The Hague
The Netherlands

TxCell® Scanning Laser Delivery System
100-240 VAC 50/60 Hz
3.0A
P/N: 70206 Rev. C

DANGER!
Do not remove covers.
Shock hazard and accessible
laser radiation. Refer to qualified
laser personnel. Risk of explosion
if used in the presence of
flammable anesthetics.

REF

SN

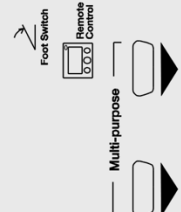

Four Switch



















































Remote Control

Multi-purpose



CE 2797
93/42/EEC

Symbols (As Applicable)

	Aiming Beam		Angle		Aspirating Probe
	Caution		Audible Signal		CE Mark
	Connector Type		Do No Use if Package is Damaged		Duration
	Duration with MicroPulse		Emergency Stop		ETL Mark
	EtO Sterile		EU Authorized Representative		Expiration Date
	Footswitch		Footswitch In		Footswitch Out
	Warning, Replace with fuses as indicated		Gauge		Protective Earth (Ground)
	Illuminating Probe		Decrease/Increase		Interval
	Interval with MicroPulse		Laser Aperture at End of Fiber		Laser Warning
	Illumination		LOT		Manufacturer
	Manufacture Date		Off		On
	Part Number		Power		Pulse Count
	Pulse Count Reset		Non-ionizing Electromagnetic Radiation		Read Information
	Remote Control		Remote Interlock		Serial Number
	Single Use		Standby		Treat
	Type B Equipment		WEE Guidance. Contact Iridex or your distributor for disposal information.		Pattern is Activated
	Temperature Limitations		Protections Against Splash Water Coming from all Directions		Protections Against Continuous Immersion
	Refer to Instruction Manual/Booklet (in blue)		Initial Power (PowerStep)		Interval between Groups

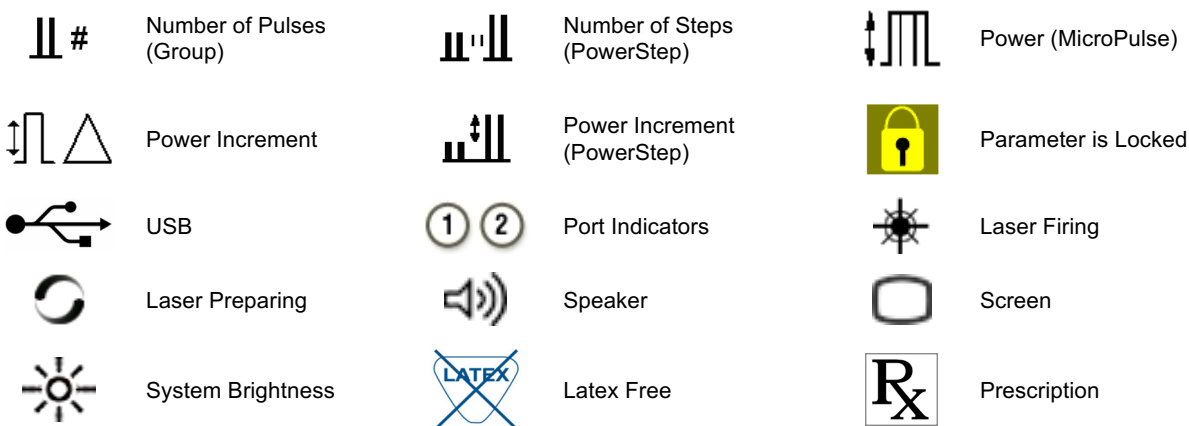

TxCeLL SSLA Specifications

Specifications	Description
Wavelength	635 nm nominal
Power	≤1 mW
Pulse duration	≤100 ms
Spot Size	Single-spot: 50 – 500 μm Multi-spot: 100 – 500 μm
Electrical	100 – 240 VAC, 50/60 Hz
Operating temperature range	10° C to 35° C (50° F to 95° F)
Storage temperature range	-20° C to 60° C (-4° F to 140° F)
Maximum recommended ambient air temperature for treatment	30° C (86° F)
Altitude	< 3000 m (9800 ft)
Relative humidity	10% to 90% (non-condensing)
Dimensions	SLA: 12 cm x 5.5 cm x 22.2 cm (4.71 in. W x 2.18 in. D x 8.75 in. H) Control Box: 26.2 cm x 7.4 cm x 33.8 cm (10.3 in. W x 2.9 in. D x 13.3 in. H)
Weight	SLA: 2.2 kg (4.8 lb.) Control Box: 3.0 kg (6.6 lb.)
Compatible lasers	IQ 532® & IQ 577®
Compatible slit lamp styles	Iridex SL 980, Iridex SL 990, Zeiss 30 SL, Zeiss SL 130 Haag-Streit BM/BQ 900 and equivalents

EMC Safety Information

The laser system (console and accessories) needs special precautions regarding EMC and needs to be installed and put into service according to the EMC information provided in this section. Portable and mobile RF communications equipment can affect this system.

This laser system has been tested and found to comply with the limits for medical devices in IEC 60601-1-2 according to the tables in this section. These limits are designed to provide reasonable protection against harmful interference in a typical medical installation.

CAUTION: *Changes or modifications to this laser system not expressly approved by the party responsible for compliance could void the user's authority to operate the equipment and may result in increased emissions or decreased immunity of the laser system.*

The wireless footswitch transmits and receives in the frequency range of 2.41GHz to 2.46GHz with a limited effective radiated power as described below. The transmissions are continuous transmissions at discrete frequencies within the transmission frequency range.

The wireless footswitch has been tested and found to comply with the limits for a Class B digital device, pursuant to Part 15 of the FCC Rules. These limits are designed to provide reasonable protection against harmful interference in a residential installation. This equipment generates, uses, and can radiate radio frequency energy and, if not installed and used in accordance with the instructions, may cause harmful interference to radio communications. However, there is no guarantee that interference will not occur in a particular installation. If the wireless footswitch does cause harmful interference to radio or television reception, which can be determined by turning the laser system off and on, the user is encouraged to try to correct the interference by one or more of the following measures:

- Reorient or relocate the receiving device.
- Increase the separation between the equipment.
- Connect the laser console into an outlet on a circuit different from that to which the receiver is connected.
- Consult Iridex Customer Service for help.

This Class B digital apparatus meets all requirements of the Canadian Interference-Causing Equipment Regulations.

Cet appareil numérique de la classe B respecte toutes les exigences du Règlement sur le matériel brouilleur du Canada.

EMC Requirements for Console and Accessories

Guidance and Manufacturer's Declaration - Electromagnetic Emissions		
This laser system (console and accessories) is intended for use in the electromagnetic environment specified below. The customer or the user of the laser system should assure that it is used in such an environment.		
Emissions Test	Compliance	
RF emissions CISPR 11	Group 1	The laser system uses RF energy only for its internal function. Therefore, its RF emissions are very low and are not likely to cause any interference in nearby electronic equipment.
RF emissions CISPR 11	Class A	
Harmonic emissions IEC 61000-3-2	Class A	
Voltage fluctuations/ Flicker emissions	Complies	
The laser system is suitable for use in all establishments, other than domestic establishments and those directly connected to the public low-voltage power supply network that supplies buildings used for domestic purposes.		

Guidance and Manufacturer's Declaration - Immunity			
This laser system (console and accessories) is intended for use in the electromagnetic environment specified below. The customer or the user of the laser system should assure that it is used in such an environment.			
Immunity Test	IEC 60601 Test Level	Compliance Level	Electromagnetic Environment - Guidance
Electrostatic discharge (ESD) IEC 61000-4-2	±6 kV contact ±8 kV air	±6 kV contact ±8 kV air	Floors should be wood, concrete, or ceramic tile. If floors are covered with synthetic material, the relative humidity should be at least 30%.
Electrical fast transient/burst IEC 61000-4-4	±2 kV for power supply lines ±1 kV for input/output lines	±2 kV for power supply lines Not Applicable	Mains power quality should be that of a typical commercial or hospital environment.
Surge IEC 61000-4-5	±1 kV differential mode ±2 kV common mode	±1 kV differential mode ±2 kV common mode	Mains power quality should be that of a typical commercial or hospital environment.
Voltage dips, short interruptions and voltage variations on power supply input lines IEC 61000-4-11	<5% U_T (>95% dip in U_T) for 0.5 cycle 40% U_T (60% dip in U_T) for 5 cycles 70% U_T (30% dip in U_T) for 25 cycles <5% U_T (>95% dip in U_T) for 5 sec	<5% U_T (>95% dip in U_T) for 0.5 cycle 40% U_T (60% dip in U_T) for 5 cycles 70% U_T (30% dip in U_T) for 25 cycles <5% U_T (>95% dip in U_T) for 5 sec	Mains power quality should be that of a typical commercial or hospital environment. If the user or the laser system requires continued operation during power mains interruptions, it is recommended that the laser system be powered from an uninterruptible power supply or a battery.

(50/60 Hz) magnetic field IEC 61000-4-8	3 A/m	3 A/m	Power frequency magnetic fields should be at levels characteristic of a typical location in a typical commercial or hospital environment.
NOTE: U_T is the AC mains voltage prior to application of the test level.			

Guidance and Manufacturer's Declaration - Electromagnetic Immunity			
The wireless footswitch is intended for use in the electromagnetic environment specified below. The customer or the user of the wireless footswitch should assure that it is used in such an environment.			
Immunity Test	IEC 60601 Test Level	Compliance Level	Electromagnetic Environment - Guidance
Conducted RF IEC-61000-4-6 Radiated RF IEC 61000-4-3	3 Vrms 150 kHz to 80 MHz 3 V/m 80 MHz to 2.5 GHz	3 Vrms 3 V/m	<p>Portable and mobile RF communications equipment should be used no closer to any part of the laser system, including cables, than the recommended separation distance calculated from the equation applicable to the frequency of the transmitter.</p> <p>Recommended separation distance:</p> $d = 1.2 \sqrt{P}$ $d = 1.2 \sqrt{P} \text{ 80MHz to 800 MHz}$ $d = 2.3 \sqrt{P} \text{ 800 MHz to 2.5 GHz}$ <p>Where P is the maximum output power rating of the transmitter in watts (W) according to the transmitter manufacturer and d is the recommended separation distance in meters (m).^a</p> <p>Fields strengths from fixed RF transmitters, as determined by an electromagnetic site survey, should be less than the compliance level in each frequency range.^b</p> <p>Interference may occur in the vicinity of equipment marked with the following symbol:</p> 
NOTE 1: At 80 MHz and 800 MHz, the higher frequency range applies.			
NOTE 2: These guidelines may not apply in all situations. Electromagnetic propagation is affected by absorption and reflection from structures, objects, and people.			
<p>a:Field strengths from fixed transmitters, such as base stations for radio (cellular/cordless) telephones and land mobile radios, amateur radio, AM and FM radio broadcast and TV broadcast cannot be predicted theoretically with accuracy. To assess the electromagnetic environment due to fixed RF transmitters, an electromagnetic site survey should be considered. If the measured field strength in the location in which the laser system is used exceeds the applicable RF compliance level above, the laser system should be observed to verify normal operation. If abnormal performance is observed, additional measures may be necessary, such as reorienting or relocating the laser system.</p> <p>b:Over the frequency range 150 kHz to 80 MHz, field strengths should be less than 3 V/m.</p>			

Recommended Separation Distances between Portable and Mobile RF Communications Equipment and the Wireless Footswitch

The wireless footswitch is intended for use in an electromagnetic environment in which radiated RF disturbances are controlled. The customer or the user of the wireless footswitch can help prevent electromagnetic interference by maintaining a minimum distance between portable and mobile RF communications equipment (transmitters) and the wireless footswitch as recommended below, according to the maximum output power of the communications equipment.

Rated Maximum Output Power of Transmitter (W)	Separation Distance According to Frequency of Transmitter (m)		
	150 kHz to 80 MHz $d = 1.2 \sqrt{P}$	80 MHz to 800 MHz $d = 1.2 \sqrt{P}$	800 MHz to 2.5 GHz $d = 2.3 \sqrt{P}$
0.01	0.12	0.12	0.23
0.1	0.37	0.37	0.74
1	1.2	1.2	2.3
10	3.7	3.7	7.4
100	12	12	2.3

For transmitters rated at a maximum output power not listed above, the recommended separation distance d in meters (m) can be estimated using the equation applicable to the frequency of the transmitter, where P is the maximum output power rating of the transmitter in watts (W) according to the transmitter manufacturer.

NOTE 1: At 80 MHz and 800 MHz, the separation distance for the higher frequency range applies.

NOTE 2: These guidelines may not apply in all situations. Electromagnetic propagation is affected by absorption and reflection from structures, objects, and people.